

AGGREGSCRUB[®] P150

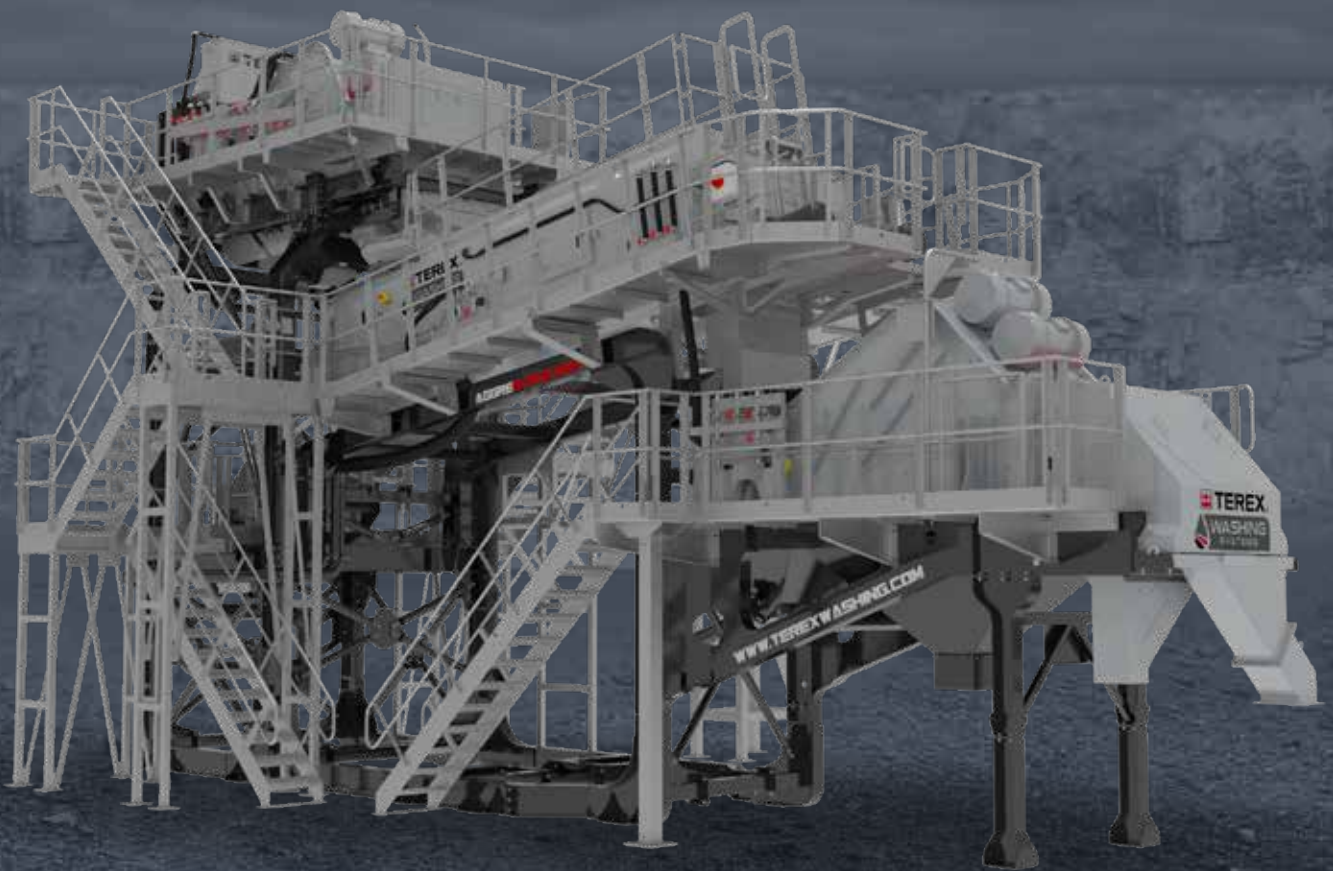

The core of any wet processing plant

Feed of up to 150tph capable of producing
1 oversize, 2 slurries & 3 aggregates

AGGREGATES



RECYCLING



INDUSTRIAL SANDS



MINING



THE CORE OF ANY WET PROCESSING PLANT

The Terex AggreScrub PreScreen is the core of your wet processing plant. Particularly suited for C&D and excavation applications, combining rinsing, scrubbing & sizing and removal of light weight contaminants, all on a modular chassis, with CE approval.

1 Machine
6 Products
UP TO 150 Tonnes P/H

Twin Shaft Independent Drive Logwasher

Both shafts within the Terex Washing logwasher are fitted with independent motors, with gear drives. This means our logwasher has the ability to start under load, saving on downtime due to unnecessary clean outs caused by emergency shut downs.

Narrow Shaft Design

Results in a better 'stone on stone' scrubbing giving better throughputs and a cleaner aggregate product and eliminates the need for secondary scrubbing on high clay bound or dirty material

Integrated Sump & Pump

Making the AggreScrub the perfect choice for the core of your wet processing plant. The sump collects all fines and water from the pre screen, the logwasher and aggregate sizing screen, which allows for simple further processing in a sand plant to produce your sand product.

Right from the start

Our integrated wash box means that we control how the material feeds to the screen. Our wash box ensures an even spread on the screen deck which maintains a low material depth meaning greater fines recovery for your process and more saleable product.

Screen Performance

With over 60 years of history Terex are a world leader in screen box design and manufacture. We maximise power transmission to the screen ensuring the most efficient material separation and minimal material 'carry over', making our screens the most efficient for your process, resulting in maximum saleable product production

Operator Safety

The AggreScrub is designed with your operator in mind with class leading access all round the machine resulting in a safer working environment

Screen Design

The Terex screen has a patented 'roll away' front chute which gives unrivalled screen access for maintenance purposes. Our 'Huck Bolt' construction of the screen frame eliminates potential weld failures resulting in longer screen lifetimes.

Integrated Oversized Conveyor

Designed with your process in mind, the oversized conveyor eliminates the need for additional prescreening of your material. With no separate prescreen, the AggreScrub will also maximise sand recovery as no fines are potential lost in prescreen operation, which maximises saleable product

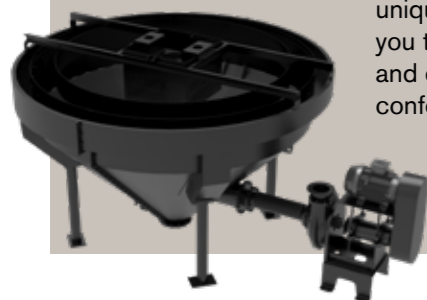
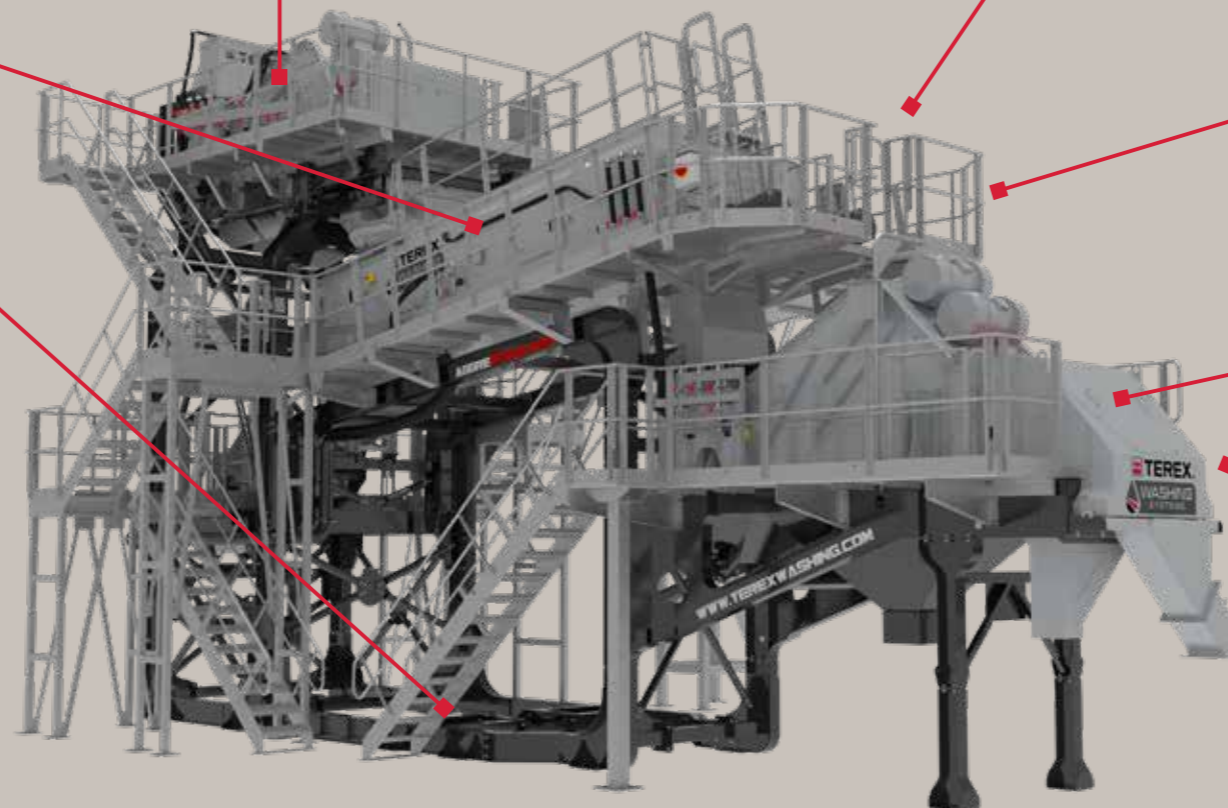

The Terex Washing Pre Wash has unique design features which allows you to process difficult/ dirty material and ensure production of sand products conforming to strict specifications.



WASHING AS IT SHOULD BE



CHECK OUT TEREX WASHING SYSTEMS
VIDEOS ON YOUTUBE:
www.youtube.com/terexwashingsystems



TEREX WASHING SYSTEMS

FARLOUGH SITE

32 Farlough Road,
Dungannon,
Co. Tyrone,
Northern Ireland, BT71 4DT

Tel: +44(0) 28 8771 8500
Email: TWS.sales@terex.com



An authorized dealer of Terex Washing Systems
44109 Yale Road West, Chilliwack, B.C. V2R 3Z9
[t] 1-888-852-9021
[e] info@foremanequipment.com
[w] www.foremanequipment.com

Effective Date: October 2022 Product specifications and prices are subject to change without notice or obligation. The photographs and/or drawings in this document are for illustrative purposes only. Refer to the appropriate Operator's Manual for instructions on the proper use of this equipment. Failure to follow the appropriate Operator's Manual when using our equipment or to otherwise act irresponsibly may result in serious injury or death. The only warranty applicable to our equipment is the standard written warranty applicable to the particular product and sale and Terex makes no other warranty, express or implied. Products and services listed may be trademarks, service marks, or trade names of Terex Corporation and/or its subsidiaries in the USA and other countries. All rights are reserved. Terex is a registered trademark of Terex Corporation in the USA and many other countries.
© 2022 Terex Corporation.